

## PRODUCT BRIEF

# Managed Internet Service

High Speed Dedicated Access, World-Class Reliability

Your business relies on the Internet for many critical operations – electronic commerce, e-mail, remote access productivity and much more. Intended for corporate and hosting sites, resellers and ISP's, AT&T Managed Internet Service helps you consolidate management of your Internet applications with high speed dedicated access, world-class reliability and optimal performance, scalability and security.

### Around-the-Clock Access – and Access Options

AT&T Managed Internet Service provides a dedicated Internet connection, with extensive reach in the continental U.S., for your business 24 hours a day. You can select our completely AT&T-managed solution – or choose to manage components of your Internet access

solution yourself. Either way, we proactively monitor your Internet access around the clock and provide enhanced security features to help protect your valuable network resources.

Built into AT&T Managed Internet Service is flexibility, with a wide range of access speeds, access methods and options.

- Access Speeds: 56 Kbps - 2.5 Gbps (OC48)\*
- Access Methods: Private Line, Frame Relay, ATM, Ethernet Access and Integrated Access (voice and data)
- Service Components: Customer Premises Equipment (router, modem and CSU/DSU), CPE management, monitoring and maintenance, Primary and Secondary DNS, Packet Filtering, Usage Reports, Local Access, Electronic Servicing capabilities

### Benefits

- Combines dedicated Internet access with end-to-end expert management from AT&T
- Provides AT&T reliability backed by industry-leading service level guarantees
- Includes 24x7 customer support, technical assistance and proactive monitoring
- Provides flexible access speeds and options, including Ethernet, VoIP and access redundancy options
- Improves productivity with MPLS Private Network Transport

### Features

- Managed service with AT&T or customer provided CPE
- Traffic carried anywhere on the Internet
- Wide variety of access speeds, methods and options
- Dedicated port into AT&T's OC48/OC192 Common Backbone – no single core backbone point of failure
- Industry-leading SLAs
- Choice of flat rate or usage-based billing
- BusinessDirect<sup>SM</sup> portal access to servicing, reporting and tools

### AT&T MIS with Customer-Provided CPE

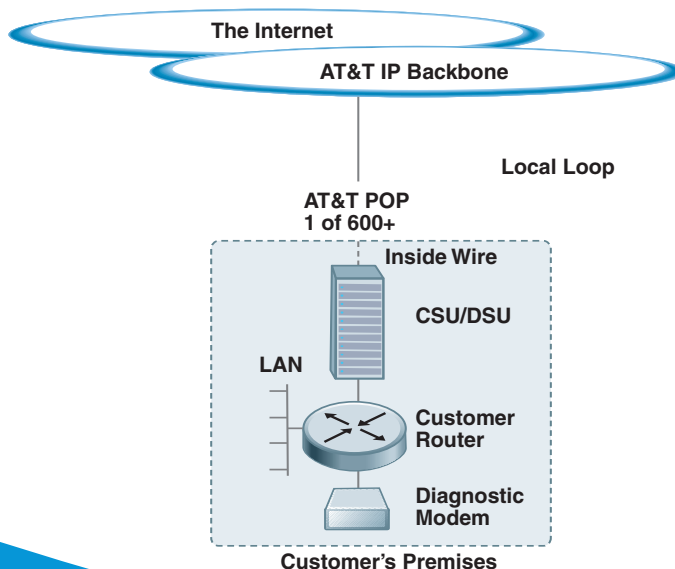

 **Communication Systems International Incorporated**



**Midwest 5 Star**  
Solution Provider  
★★★★★

- Options: Flat-rate or Usage-based billing, Class of Service, MPLS Private Network Transport, Security Solutions, Access Redundancy Options, Managed Internet Service with VoIP

### **End-to-End Management As You Need It**

More than just an Internet connection, AT&T Managed Internet Service is a complete solution that combines reliable access and world-class 24x7 support. You gain the quality and performance you need to conduct business over the Internet with confidence.

AT&T Managed Internet Service incorporates convenience, resources and flexibility in a completely vendor-provided Internet solution, easing the management headaches associated with rapidly growing Internet use. You can take advantage of managed, high-speed, end-to-end Internet connectivity, knowing that AT&T is there with proactive monitoring and expert technical assistance.

In addition, we provide and maintain full management and operational control of the necessary equipment, significantly lessening your network management burden. Or, if you prefer, you may supply and manage your own CPE.

### **Reliability in the Backbone – and More**

AT&T is a leading Tier 1 Internet Service Provider with a high performing OC48/OC192 IP Backbone. As the market leader in high-capacity OCX solutions, AT&T can offer you world-class reliability when your communications race to the Internet.

The backbone's multiple-ring design provides alternate routes between backbone nodes for enhanced service reliability. All routers are deployed in a redundant configuration, with fully redundant power supplies and route switch processors. They're equipped with battery backup equipment and emergency generators. In fact, the architecture enables immediate rerouting around outages for almost instantaneous service restoration.

Reliability doesn't stop there. The Managed Internet Service Access Redundancy Options optimize the performance of multiple, dedicated Internet circuits while eliminating single points of failure in the access circuits and routers on your site and in the AT&T IP Backbone node where your connection is terminated. The result is even higher performance with greater levels of reliability.

### **Guarantees to Back Up Our Service**

AT&T Managed Internet Service is dedicated to providing highly reliable performance. Backing up the service are strong AT&T SLAs that provide guarantees of service availability of 100%, data delivery of 99.95%, a network wide, monthly average delay of just 37 milliseconds, and a network wide average packet loss of 0.05%. In addition, we have guaranteed provisioning intervals, so your service will be up and running when you need it.

To keep your competitive edge, utilize AT&T Managed Internet Service to help you conduct business on the Internet with confidence, reliability and flexibility.

\*Some speeds may not be available in all areas.

